

## Simple Medical(Shenzhen)Limited Instruction For Use

SIMPLE Dual Upright OA Knee Brace M1

Model: 11018 & 11019 Size: S, M, L, XL

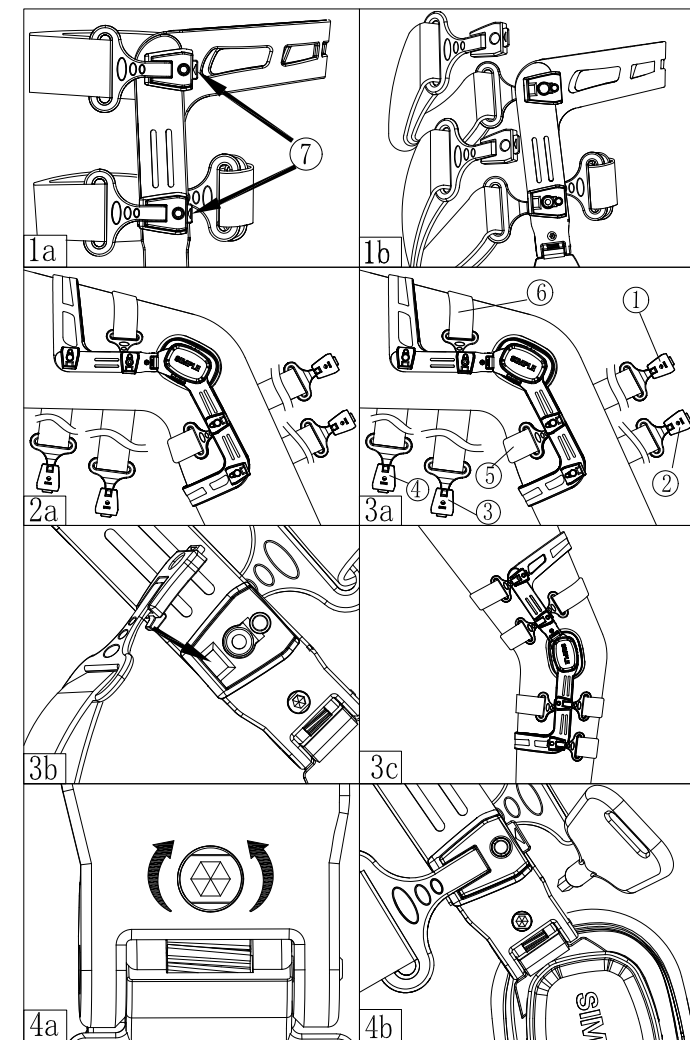

### PRODUCT STRUCTURE AND PERFORMANCE

The support is mainly composed of aluminum alloy bracket, macromolecule material fittings, band, lining and fittings. The product has a streamlined lightweight design with support and a comfortable non-slip lining. The unique patented hinge technology can effectively reduce the load of knee varus or valgus. Through the optimization of single column support and unique knee varus or valgus angle adjustment, it helps to relieve the pain and pressure points of the knee joint. The special contour design provides smooth mobility for the legs, improves the protection of the ligaments, and the patented fast fastening system can be applied quickly

### INDICATIONS:

- Patients with knee varus support and mild to severe osteoarthritis and ligament instability on one knee.

### APPLICATION INSTRUCTIONS

**STEP 1:** Loosen the fastening belt and press and hold button 7 to remove the buckle from the base in turn (figure 1a~1b).

**STEP 2:** Sit with your legs in the brace, knees slightly bent, center of hinge aligned with center of knee (Fig 2a).

**STEP 3:** Tighten the straps When fastening the straps; the hinge should be kept in a supporting state to prevent movement. Click the buckles in place to ensure that the position of the straps is tight(Fig 3a~3c).The sequence of fixed straps is as follows:

**Strap#1:** Attach the upper calf position

**Strap#2:** Attach the lower leg.

**Strap#3:** Attach the lower leg of the thigh.

**Strap#4:** Tie the upper thighs, but not too tight. Excessive tightening may limit circulation or cause the bracket to move downward

**Strap#5:** Fasten the back strap and tighten it.

**Strap#6:** Fasten the front strap and tighten it.

**STEP 3.1.** Adjust the tightness of each strap for comfort.

**NOTICE:** From the side, the hinge should be slightly behind the midline of the knee. The band #1, #3 and #5 will affect the tightness of the whole product .In order to ensure good movement, it is normal for the brace to drop during walking. Adjust the position of the straps and bracing if necessary. After the setting is completed, the braces can be taken off by buckles without relaxing and tightening each fixed belt. (Fig 3c)

**STEP 4.** Product initial installation: knee bend30 °, turn hinge center screw 1 / 8 (important) clockwise with adjustment tool to increase unloading on the outer side or unclockwise 1 / 8 turn to the center. This is the best starting point for initial use (fig 4a ~4b).

**STEP 4-1.** Stand and walk short distances to ensure comfort after each adjustment and adjustment of support. If there is any discomfort in the knee or leg, adjust the angle slightly back.

If more unloading is required, turn hinge center screws no more than 1/8 turn. Walk after adjustment and check for comfort.

**\* IMPORTANT: excessive adjustment of hinge center screws may cause discomfort or skin pressure problems. Please adjust carefully**

**"Wearing time":** Gradually increase the wearing time of the brace and adjust the wearing time of the brace if the body allows.

**PREOPERATIVE WEARING TIME:** the first wearing time starts from 30 minutes and gradually increases to no less than 2 hours per day according to the degree of body adaptation. The supporting Angle of hinge can be adjusted again in condition of no discomfort.

**POSTOPERATIVE WEARING:** The standard of wearing should be decided by the doctor, including the angle of hinge support, the angle of flexion and extension, and the time of wearing every day.

The pain caused by osteoarthritis takes time to subside. Wearing a brace regularly for weight-bearing activities (such as walking) will start to feel lighter as it will reduce joint load. This may require wearing it for weeks or more to reduce joint load until your primary care physician allows you to remove the brace.

### RANGE OF MOTION ADJUSTMENTS

Start from the standard 0 °. Additional flexion and extension angle

accessories can be installed and they are fitted by the doctor as required. Optional extension angles include 5°, 10°, 15°, 20°, and 25°; Optional flexion angles include 30°, 45°, 60°, 75°, and 90°.

**\*Please purchase and use the product under the guidance of your doctor or professional.**

**IMPORTANT: Both hinges must be set to same extension and/or flexion settings. For 0° extension limiting, 0° extension stops must be used**

### STRAP LENGTH ADJUSTMENT

To determine the required length, open the cushion belt, open the end of the binding belt, separate the Velcro and the binding belt, cut to the required length, and then attach the cushion to the end of the binding belt.

### TO CHANGE AN EXTENSION STOP:

Unscrew the screw on the front of the hinge cap. Shake out the extension stop. Insert another extension stop into the front of the hinge and replace the screw. Repeat for the opposite hinge.

### TO INSERT A FLEXION STOP:

Insert a flexion stop into the back of the hinge and use the extra screw that is attached to the flexion/extension stop tree to secure. Repeat for the opposite hinge.

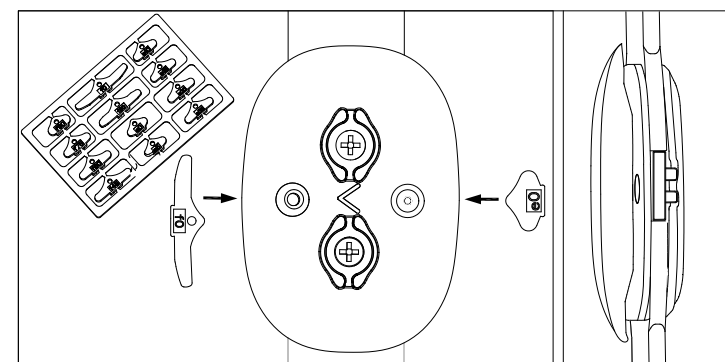

### CARE AND MAINTENANCE

Lining can use neutral detergent and 30°C water washed by hand, and natural dry. Do not use clothes dryer or other heat source for drying.

Metal parts should not be washed with water. Hinges can be lubricated with dry silicone spray

**WARNINGS:** If you experience pain, swelling, sensory changes, or discomfort with this product, Please stop using and contact your doctor.

### FOR SINGLE PATIENT USE ONLY

**NOTICE:** The device is a one-element holistic treatment program managed by medical professionals. There is no guarantee that damage can be prevented by using the device.

### BASIC PRODUCT ENVIRONMENT

- 1) Ambient temperature: -15 ~ 60°C
- 2) Relative humidity: ≤ 80%

### PRODUCT MATERIALS

- 1) Metal support: aluminum alloy/stainless steel
- 2) Buckle: ABS/ polyester thermoplastic elastomer
- 3) Angle adjustment accessories: nylon + glass fiber
- 4) Strap/pad: nylon/polyurethane/polyester /EVA/ Velcro

### CONTRAINDICATION

- ⚠ Use with caution for unstable fractures;

- ⚠ Use with caution in osteoporosis;
- ⚠ Use with caution for cognitive impairment;
- ⚠ Use with caution for bony ankylosis;

### STORAGE, TRANSPORTATION AND EXPIRY DATE OF PRODUCTS

- 1) Term of validity: 5 years.
- 2) Storage of the product: please put it in a dry and clean room before use to ensure indoor ventilation.
- 3) Transportation: the product shall be dust-proof, moisture-proof and pollution-proof during storage and transportation.

### WASTE DISPOSAL

Disposal of wrapping paper (bags): please dispose of the packaging of this product according to the local laws.

### SYMBOL AND PICTURE DESCRIPTION

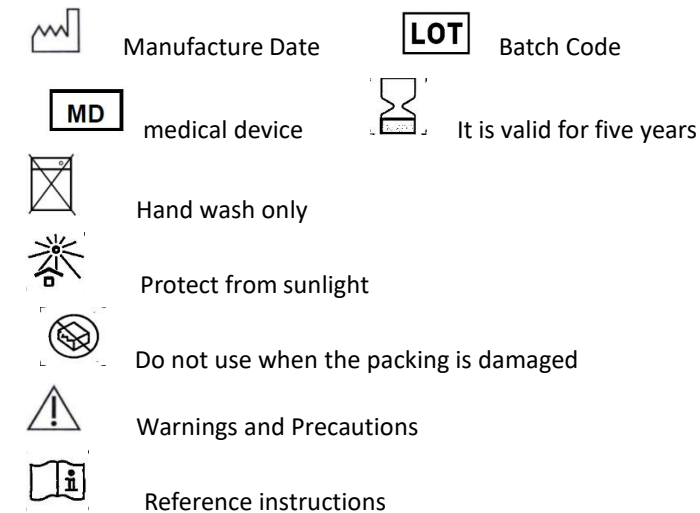

### ACCESSORIES LIST

- Instructions ----- 1 copy
- Knee pad ---- - 2 PCS (sets)
- Angle adjusting accessories ----2 PCS (sets)
- Angle adjustment key ---- 1PCS

### AFTER-SALES WARRANTY

Warranty: all products from the date of purchase as the original date, normal wear and tear of the product in the use of the process is not considered defective.

The following parts from the date of purchase to the warranty period, if there is any material or process defects, please contact your seller directly, Simple medical will complete or partial repair or replacement of equipment and accessories.

Metal support ---- -- 1 year

**Simple Medical (Shenzhen) Limited**  
Address: 519 Wisdom Valley, No.1010 Bulong Road, Minzhi Street, Longhua District, Shenzhen, China.518131  
Tel : +86-755-86038563

Web: www.simplemedical.cn E-mail: service@simplegroup.net



Fascinatio Boulevard 522 ,Unit.1.7,2909VA Capelle aan den IJssel ,The Netherlands  
Tel : +31(0)10-3034500

\*Please refer to the Instructions before usage



## 深圳简单医疗科技有限公司 产品说明书

### 膝部固定器

产品型号：11018&11019 产品规格：S, M, L, XL

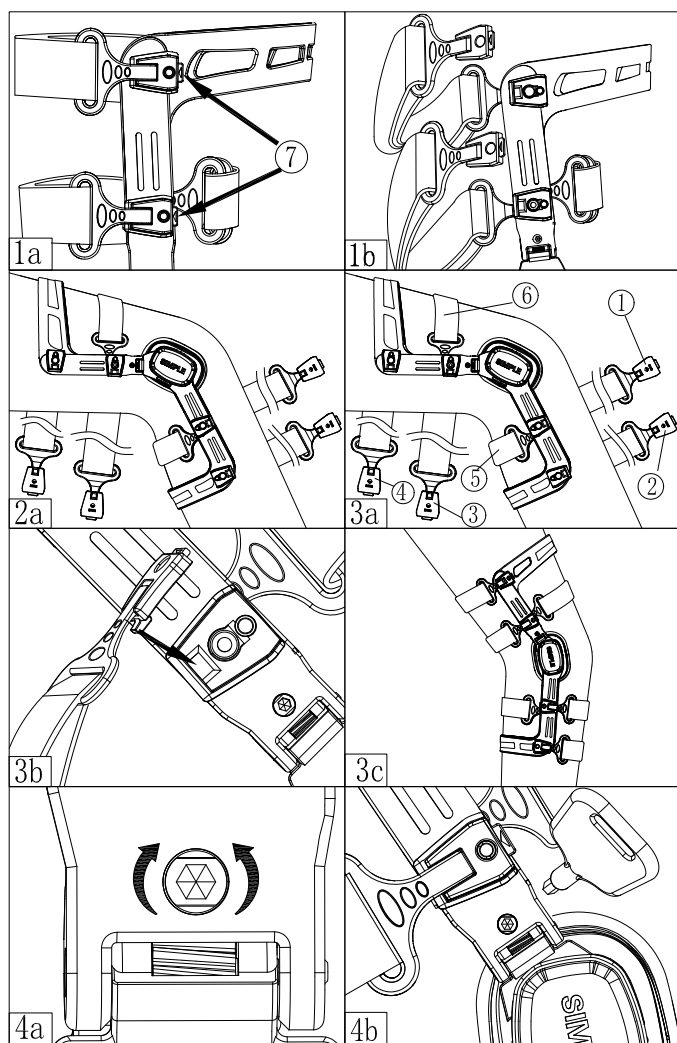

#### 一. 产品结构及性能

采用高分子材料、织物、皮革、金属等材料制成。产品采用流线型轻量化的设计，设置有支撑器和舒适的防滑衬里。通过支撑器使得膝关节与大/小腿有妥帖的保护。独家专利技术铰链，能够有效减轻膝内翻或外翻的负荷。将单立柱支撑与独特的膝内翻/外翻角度调整的优化，有助于缓解膝关节的疼痛和压力点。特别的轮廓设计，为腿部提供顺畅的流动性，提高韧带的保护性，专利技术的快速搭扣系统，能够快速穿戴，产品适合多种用途，有效保障患者得到良好的恢复。

#### 二. 预期范围

用于膝部部位的外固定或支撑。

#### 三. 适应症

• 膝关节内外翻支撑和单膝轻度到重度骨性关节炎及韧带不稳定患者

#### 四. 应用说明

**步骤 1:** 松开固定带，按住按钮 7 依次将搭扣从扣座上取出（图 1a~1b）。

**步骤 2:** 坐着把腿放进固定器内，膝盖稍微弯曲，铰链中心位置与膝盖中心位置对齐（图 2a）。

**步骤 3:** 紧固绑带。在紧固绑带时，铰链处应保持支撑状态防止移动。将搭扣扣住，搭扣要扣到位，保证搭扣位置紧固。（图 3a~3c）系绑带的顺序如下：

绑带#1：系上小腿上部。

绑带#2：系下小腿下部。

绑带#3：系下大腿下部。

绑带#4：系大腿上部，不要过紧。过紧可能会导致血液循环缓慢或支架向下移动。

绑带#5：系紧后绑带及紧固。

绑带#6：系紧前绑带及紧固。

**步骤 3.1:** 调整各个绑带的松紧度，舒适即可。

注意：从侧面看，铰链应在膝盖中线稍靠后一点。绑带#1, #3 和#5 将影响整个产品的穿戴松紧度。（图 3a）为了确保适当的活动，在行走时，支架下降是正常的。必要时进行绑带和位置调整。设置完成后，固定器佩戴可以使用扣（图 3c）穿脱，不需要放松和收紧每条固定带。

**步骤 4:** 支撑的初始安装：膝盖弯曲 90°，用调整工具把铰链中心螺丝顺时针转动 1/8 圈（重要）增加外侧面的卸荷或逆时针 1/8 圈向中心卸荷。这是初次使用的最佳起点（图 4a~4b）。

**步骤 4.1:** 站立和行走短距离，以确保每次调整和校正支撑后的舒适度。如果膝关节或腿部有任何不适，请稍微向后调整角度。

如果需要更多的卸荷，可拧铰链中心螺丝不超过 1 / 8 圈，在调整后行走并检查舒适度。

#### \*重要事项:

**过度调整铰链中心螺丝可能引起不适或皮肤压力问题。请谨慎调整。**

**“穿戴时间”:** 逐渐增加支架的穿戴时间，在身体允许的状态下调整固定器的穿戴时间。

**术前穿戴时间:** 第一次穿戴时间由 30 分钟开始，根据身体的适应程度，逐渐增加到每天不少于 2 小时的穿戴时间，在身体没有不适的情况下再调整铰链的支撑角度。

**术后穿戴:** 固定器穿戴的标准应由医生来制定铰链支撑的角度和屈伸的角度及每天的穿戴时间。

骨关节炎引起的疼痛需要时间来消退。经常穿戴固定器负重活动（例如：步行），会让你开始感觉轻松，因为它会减轻关节负荷。这可能需要佩戴几个星期或以上来减轻关节负荷，直至你的主治医生同意你取下固定器。

**运动调整范围:** 支撑从标准 0° 延伸。额外的屈伸站可以安装，他们是由医生按规定或需要来安装适合的支撑。延长挡位可选 5°，10°，15°，20°，和 25° 屈曲挡位可选 30°，45°，60°，75° 和 90°。

**\*请在医生或专业人士指导下购买和使用。**

**\*重要事项:** 两个铰链必须设置为相同的扩展和/或屈曲设置。对于 0° 扩展限制，必须使用 0° 扩展停止。

#### 绑带长度调整:

确定所需长度，打开软垫带，打开绑带尾端，分开魔术贴和绑带，剪切至所需长度，再将软垫贴至绑带尾部。

#### 更改延伸限制:

松开铰链前面的螺丝，在铰链的前部插入另一个延伸限制调整配件，并更换螺丝。重复另一个铰链。

#### 插入弯曲限制:

在铰链后面插入一个弯曲调整配件，并使用附加到屈曲/扩展调整配件啊的螺钉来固定。重复另一个铰链。

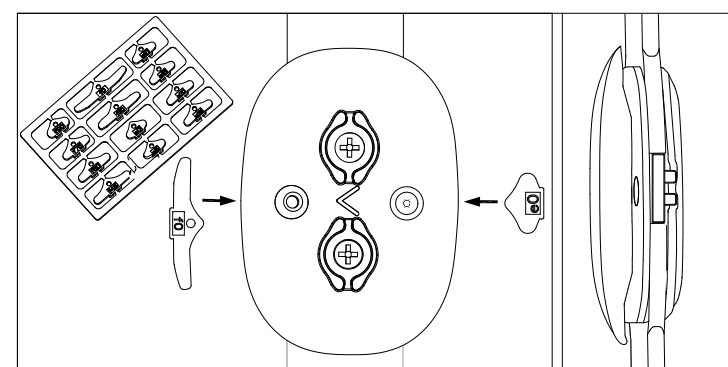

#### 保养与维护

衬里可以用中性洗涤剂和 30°C 水手洗，并自然风干。切勿放入干衣机或使用其他热源进行干燥。

金属部分不可用水清洗，铰链可用干硅胶喷雾来润滑。

#### 警告:

如果您使用此产品时感到疼痛，肿胀，感觉变化，或有不适的反应，请停止使用并联系您的医生。

仅适用于单例患者。

**注意:** 该设备是只有一个元素的整体治疗方案由医疗专业人员管理。不能保证通过使用该装置可以防止损伤。

#### 五. 产品基本环境

1) 环境温度：-15~60°C

2) 相对湿度：≤80%

#### 六. 产品材料

1) 金属支架：铝合金/不锈钢

2) 搭扣：ABS/聚酯型热塑性弹性体

3) 角度调整配件：尼龙+玻纤

4) 绑带/衬垫：尼龙/聚氨酯/聚酯/EVA/魔术贴

#### 七. 禁忌症

⚠ 非稳定性骨折慎用；

⚠ 骨质疏松症慎用；

⚠ 认知缺陷慎用；

⚠ 骨质性关节强硬等慎用；

#### 八. 产品的保管，运输及有效期

1) 产品有效期：5 年。

2) 产品的保管：未使用前请放置在干燥、清洁的室内，保证室内通风。

3) 运输：本产品存储及运输的过程，应防尘、防潮、防污染。

#### 九. 废弃物处理

包装纸（包装袋）的处理：本产品的包装请跟据所属地区法例进行弃置处理，对垃圾进行分类。

#### 十. 标记符号及图片说明

⚠ 注意，警告

🚫 禁止机洗

☀ 避免日晒

🚫 包装破损时切勿使用

🕒 有效期为 5 年

📖 参考使用说明

#### 十一. 配件清单

说明书----- 1 份

角度调整配件----- 2 个（套）

膝衬垫----- 2 个（套）

六角钥匙----- 1 个

#### 十二. 售后承诺

保修：所有产品从购买之日起为原始日期，正常磨损和撕裂的产品在使用过程中不被视为缺陷。

以下部件自购买之日起至质保期内，如果出现材料或工艺方面的缺陷，请直接联系你的销售商，简单医疗科技有限公司将对设备及附件进行完全或部分维修或更换。

金属支架----- 1 年

#### 十三. 厂家信息

【产品名称】膝部固定器

【医疗器械备案凭证编号】  
粤深械备 20180573 号

【生产备案凭证编号】  
粤莞食药监械生产备 20200057 号

【产品技术要求编号】  
粤深械备 20180573 号

【备案人】深圳简单医疗科技有限公司

【地址】深圳市龙华区民治街道新牛社区布龙路  
1010 号智慧谷创新园 519

【电话】0755-86038563

【传真】0755-86038509

【邮政编码】518131

【受托生产企业】东莞简单智造有限公司

【地址】广东省东莞市凤岗镇米亚路 1 号  
【邮政编码】523696

【电话】0769-82522823

【售后服务单位】深圳简单医疗科技有限公司

【说明书修订日期】2023 年 07 月 27 号

【网址】www.simplemedical.cn