

Simple Medical (Shenzhen) Limited Instruction For Use

Premium Post-Op Knee Brace K1

Model: 11014 Size: F

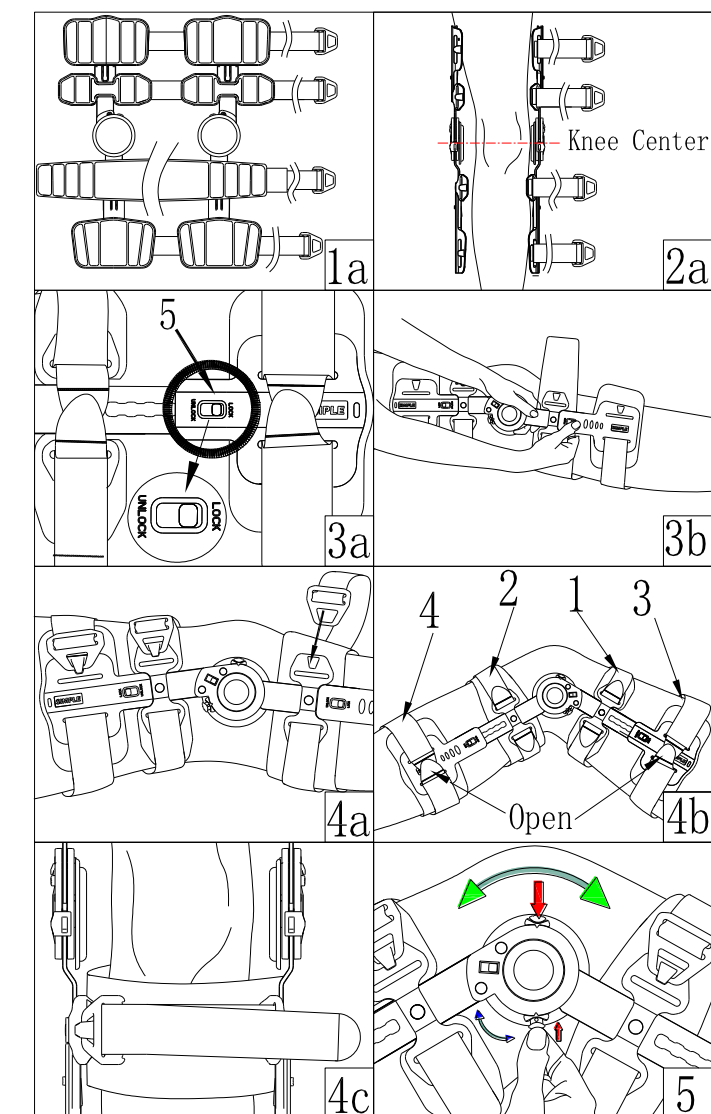

Product Structure and Performance

The brace is mainly composed of aluminum metal bracket, polymer material fittings, straps, liners and accessories. The products are designed to limit flexion and extension and control the range of post-traumatic and post-operative repair of the knee. The product adopts streamlined lightweight design with support and comfortable non-slip lining. With the support device, the knee joint and the large / lower leg are properly protected, and special contours are designed to provide smooth mobility for the legs and to improve the protection of the patient's ligaments.

INDICATIONS

- ACL, MCL, PCL, LCL repairs/injuries
- Meniscal repairs
- Tibial plateau fractures
- Patellar tendon repairs
- Osteochondral repairs
- Condylar fractures
- Sprains/strains of the knee
- HTOs(High Tibial Osteotomy)

APPLICATION INSTRUCTION

NOTICE: This product must be installed and adjusted by a doctor or professional.

STEP 1. Loosen the straps and remove the buckle from the buck base in turn (Fig 1a).

STEP 2. Place the leg in the brace, the supports on both sides of the leg should correspond to each side of the leg and the center position of the hinge should be aligned with the center position of the knee (Fig. 2a)

STEP 3. Adjust the length of the connecting rod. Push the telescopic adjustment key on the connecting rod support to the "UNLOCK" direction to unlock the connecting rod, slide the bracket to the desired length, and then push the "LOCK" direction to lock the connecting rod. When wearing, make sure that the telescopic adjustment key of the connecting rod is in the "LOCK" direction (Fig 3a~3b).

IMPORTANT 1: Doctors should adjust the length of the hinge to provide optimal knee stability. The height of the hinge wall of the thigh should be less than 5 cm from the groin, and the height of the hinge wall of the calf should not be lower than that of the joint of the calf and the Achilles tendon.

STEP 4. Fasten the straps. Secure the brace with your hand to prevent movement. And buckle the buckle in turn, buckle in place. After fastening the buckle position, adjust the straps length and liners comfort. Then the two-way fastening band on the bracket is opened and fixed to the binding belt, and the order of the fastening band (Fig 4a~4c) Fasten the straps in the following order:

Strap#1: Fasten the strap on upper calf

Strap#2: Fasten the strap on lower thigh

Strap#3: Fasten the strap on lower calf

Strap#4: Fasten the strap on upper thigh, not too tight. Too tight may lead to slow blood circulation or downward movement of the bracket.

NOTICE: From the side view, the hinge should be slightly behind the midline of the knee. In order to ensure good movement, it is normal for the brace to drop during walking. Adjust the position of the straps and bracing if necessary. After the setting is completed, the braces can be taken off by buckles without relaxing and tightening each fixed strap. (Fig 4a).

STEP 5. Adjust the scope of activity. press down the button for flexion or extension, moves to the marked angular scale as needed, and then presses the lock button to prevent the hinge wall from moving(Fig 5).

Note: The locking button on the connecting rod support of the reducer is not in the "UNLOCK" direction for a long time.

Post-operative wearing:

It is up to the doctor to set the angle of hinge brace and the angle of flexion and extension as well as the amount of time to wear each day until your attending physician agrees that you can remove the bracing.

***Please purchase and use the product under the guidance of your doctor or professional.**

* IMPORTANT 2:

- 1) Products are for individual patients and are not recommended for multiple patients.
- 2) Both hinges must be set to the same extension and / or flexion settings.
- 3) Before adjusting the brace, the patient should consult his own doctor.
- 4) This product shall be purchased and installed on prescription by a medical practitioner and worn.
- 5) Proper rehabilitation and activity improvement are also indispensable processes in safe treatment planning.

Strap length adjustment

Determine the required length, open the Velcro at the strap end, separate the Velcro at the strap end stick and strap, cut strap to the desired length, and then stick the Velcro at the strap end back to the end of the strap

LOCKING INSTRUCTION

- 1) Determine the desired locking angle
- 2) Slide the adjustment button toward the center of the hinge to lock the hinge angle.

CARE AND MAINTENANCE

Liners can use neutral detergent and 30 °C water washed by hand, and natural dry. Do not use clothes dryer or other heat source for drying.

Metal parts should not be washed with water.

WARNINGS:

If you feel pain, swelling, change of sensation, or discomfort when using this product, please stop using it and contact your doctor.

Basic application environment

- 1) Ambient temperature: -15 ~ 60 °C
- 2)Relative humidity:≤ 80%

Product materials

- 1)Metal bracket: aluminum alloy/stainless steel
- 2)plastic bracket: polyamide
- 3)Button / buckle: poly formaldehyde
- 4)Accessories: nylon glass fiber
- 5)Strap/pad: nylon / polyurethane / polyester / EVA/ magic paste

Contraindication

- ⚠ Use with caution for unstable fractures;
- ⚠ Use with caution in osteoporosis;
- ⚠ Use with caution for cognitive impairment;
- ⚠ Use with caution for bony ankylosis;

Storage, transportation and expiry date of products

- 1) Term of validity: 5 years.
- 2) Storage of the product: please put it in a dry and clean room before use to ensure indoor ventilation.
- 3) Transportation: the product shall be dustproof, moisture-proof and pollution-proof during storage and transportation.

Waste disposal

Disposal of wrapping paper (bags): please dispose of the packaging of this product according to the local laws.

Symbol and picture description

- Manufacture Date
- Batch Code
- medical device
- CE Symbol
- Protect from sunlight
- Hand wash only
- Do not use when the packing is damaged
- Warnings and Precautions
- Reference instructions

Accessories list

Instructions ----- 1 copy

After-sales warranty

Warranty: all products from the date of purchase as the original date, normal wear and tear of the product in the use of the process is not considered defective.

The following parts from the date of purchase to the warranty period, if there is any material or process defects, please contact your seller directly, Simple medical will completely or partially repair or replace the braces and accessories.

Metal bracket ---- 1 year

Simple Medical (Shenzhen) Limited
Address: 519 Wisdom Valley, No.1010 Bulong Road, Minzhi Street, Longhua District, Shenzhen, China.518109
Tel : +86-755-86038563
Web: www.simplemedical.cn
E-mail: info@simplemedicla.cn`

SUNGO Europe B.V.

Olympisch Stadion 24, 1076DE Amsterdam, Netherlands
***Please refer to the Instructions before usage**

深圳简单医疗科技有限公司 产品说明书

膝部固定器

产品型号：11014 产品规格：F

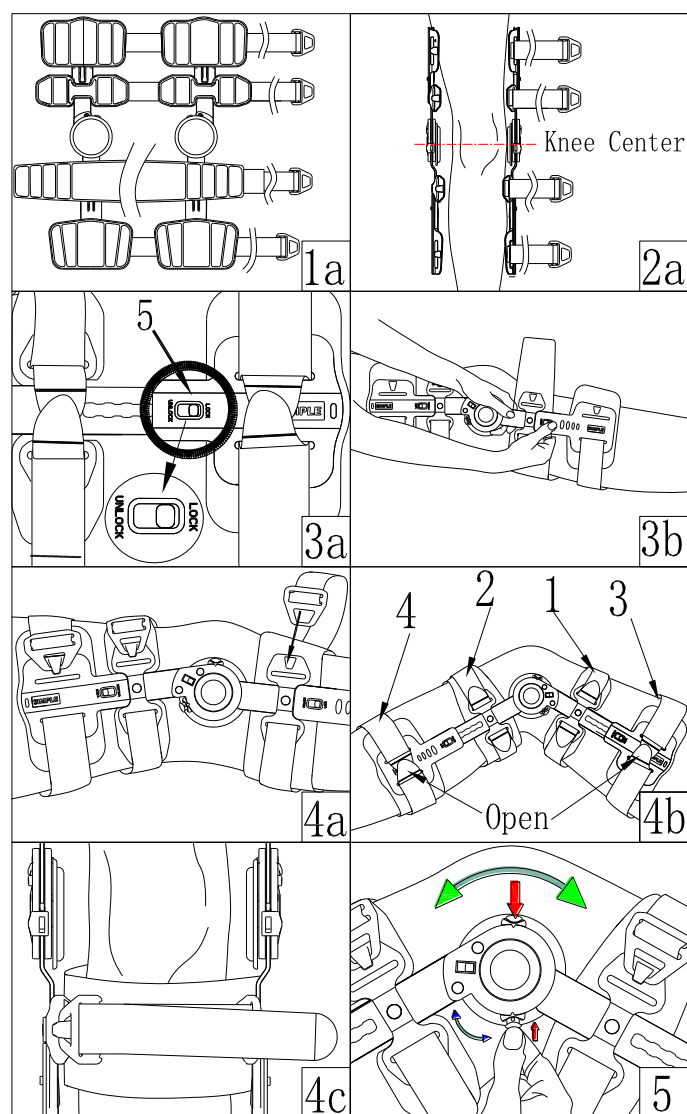

一. 产品结构及性能

支具主要由铝合金支架，高分子材料配件，绑带，衬里及配件等组成。产品用于限制屈伸和伸展，控制膝盖创伤后以及手术后修复的活动范围。产品采用流线型轻量化的设计。设置有支撑器和舒适的防滑衬里，通过支撑器使得膝关节与大/小腿有妥帖的保护，特别的轮廓设计，为腿部提供顺畅的流动性和提高患者的韧带保护性。

二. 适应症

- 前交叉韧带 (ACL), 后十字韧带 (PCL), 内侧副韧带 (MCL), 外侧副韧带 (LCL) 修复/损伤
- 半月板修复
- 胫骨平台骨折
- 髌腱修复
- 骨软骨修复
- 髌突骨折
- 膝关节扭伤/劳损
- HTO (胫骨高位截骨术)

三. 应用说明

注意：本产品须由医生或专业人员来安装和调整。

步骤 1: 松开固定带，依次将搭扣从扣座上取出 (图 1a)。
步骤 2: 把腿放进支具内，两边支架应在腿部两侧相对应且铰链中心位置与膝盖中心位置对齐 (图 2a)。

步骤 3: 调整连杆的长度。把连杆支架上的伸缩调整键往“UNLOCK”方向推为解锁连杆，滑动支架到所需的长度，再往“LOCK”方向推来锁住连杆。穿戴时请确保连杆的伸缩调整键处于“LOCK”位置上 (图 3a~3b)。

重要事项 1: 医生调整好铰链的长度，已提供最佳的膝盖稳定性。大腿铰链壁的高度应离腹股沟的距离≤5cm，小腿铰链壁的高度不能低于小腿/跟腱结合处。

步骤 4: 紧固绑带。用手固定住支具防止移动。并依次扣住搭扣，搭扣要扣到位。搭扣位置紧固后，调整好绑带长度和软垫的舒适度。再将支架上的双向固定带打开并固定在绑带上，最后紧固绑带 (图 4a~4c) 系绑带的顺序如下：

绑带#1: 系上小腿上部。

绑带#2: 系大腿下部。

绑带#3: 系下小腿下部。

绑带#4: 系大腿上部，不要过紧。过紧可能会导致血液循环缓慢或支架向下移动。注意：从侧面看，铰链应在膝盖中线偏后位置。为了确保适当的活动，在行走时，支架下降是正常的。必要时进行绑带和位置调整。设置完成后，支具佩戴可以使用扣 (图 4a) 穿脱，不需要放松和收紧每条固定带。

步骤 5: 调整活动范围。按下屈伸或伸展的按钮，根据需要移动到标示的角度刻度上，再按下卡盘上的锁住按键以防止铰链壁移动 (图 5)。

注意：大小腿连杆支架上的锁住按键请勿长时间处于“UNLOCK”位置上。

术后穿戴时间：支具穿戴的标准应由医生来制定铰链支撑的角度和屈伸的角度以及每天的穿戴时间，直至你的主治医生同意你取下支具。

***请在医生或专业人士指导下购买和使用。**

*重要事项 2:

- 1) 产品供单个患者使用，不推荐用于多个患者。
- 2) 两个铰链必须设置为相同的扩展和/或屈曲设置。
- 3) 在调整矫形器之前，患者应咨询自己的医生。
- 4) 本产品须由执业医师开处方购买并安装穿戴。
- 5) 妥善的康复和活动改良也是安全治疗计划中不可或缺的过程。

绑带长度调整

确定所需长度，打开尾端的绑带头魔术贴，分开魔术贴和绑带剪切至所需长度，再将绑带头贴回至绑带尾部。

锁紧说明

- 1) 确定所需的锁定角度。
- 2) 朝铰链中心滑动缩进按钮以锁定铰链角度。

保养与维护

衬里可以用中性洗涤剂和 30℃ 水手洗，并自然风干。切勿放入干衣机或使用其他热源进行干燥。

金属部分不可用水清洗。

警告：如果您在使用此产品时感到疼痛，肿胀，发生变化，或有不适的反应，请停止使用并立即联系您的医生。

四. 产品基本环境

- 1) 环境温度：-15~60℃
- 2) 相对湿度：≤80%

五. 产品材料

- 1) 金属支架：铝合金/不锈钢
- 2) 塑胶支架：聚酰胺
- 3) 按钮/搭扣：聚甲醛
- 4) 配件：尼龙/玻纤
- 5) 绑带/衬垫：尼龙/聚氨酯/聚酯/EVA/魔术贴

六. 禁忌症

- ⚠ 非稳定性骨折慎用；
- ⚠ 骨质疏松症慎用；
- ⚠ 认知缺陷慎用；
- ⚠ 骨质性关节强硬等慎用；

七. 产品的保管，运输及有效期

- 1) 产品有效期：5 年。
- 2) 产品的保管：未使用前请放置在干燥、清洁的室内，保证室内通风。
- 3) 运输：本产品储存及运输的过程，应防尘、防潮、防污染。

八. 废弃物处理

包装纸 (包装袋) 的处理：本产品的包装请跟据所属地区法例进行弃置处理，对垃圾进行分类。

九. 标记符号及图片说明

⚠ 注意，警告

🚫 禁止机洗

☀ 避免日晒

🚫 包装破损时切勿使用

🕒 有效期为 5 年

📖 参考使用说明

十. 配件清单

说明书----- 1 份

十一. 售后承诺

保修：所有产品从购买之日起为原始日期，正常磨损和撕裂的产品在使用过程中不被视为缺陷。

以下部件自购买之日起至质保期内，如果出现材料或工艺方面的缺陷，请直接联系你的销售商，简单医疗科技有限公司将对设备及附件进行完全或部分维修或更换。

金属支架----- 1 年

十二. 厂家信息

【产品名称】膝部固定器

【医疗器械备案凭证编号】

粤深械备 20180573 号

【生产备案凭证编号】

粤深食药监械生产备 20170002 号

【产品技术要求编号】

粤深械备 20180573 号

【备案人】深圳简单医疗科技有限公司

【生产企业】深圳简单医疗科技有限公司

【地址】深圳市龙华区民治街道新牛社区布龙路

1010 号智慧谷创新园 519

【电话】0755-86038563

【传真】0755-86038509

【邮政编码】518109

【售后服务单位】深圳简单医疗科技有限公司

【说明书修订日期】2020 年 07 月 02 号

【网址】www.simplemedical.cn

